

THE INHERITANCE OF SICKLE-CELL ANAEMIA IN MAN¹

W. H. TALIAFERRO AND J. G. HUCK

The Johns Hopkins University, Baltimore, Maryland

Received October 29, 1923

In a recent paper, one of the authors (HUCK 1923) has given an account of a comparatively rare disease, so far described only in negroes and mulattoes, which is known as sickle-cell anaemia. The two genealogical charts which his data contain indicate so clearly that the disease is definitely inherited that they seem well worth an analysis.

Only a few salient features of the disease need to be noted here, since a full account of the history, symptomatology, treatment, etc., may be found in the paper mentioned above. The peculiar feature of the disease is the occurrence of crescentic or sickle-shaped erythrocytes when the blood is observed *in vitro*. This phenomenon is due to some alteration (probably taking place in the bone marrow) in the blood cells, and not in the serum, because, when normal red blood cells are suspended in serum from a patient suffering from sickle-cell anaemia, they are not changed, but when red blood cells from such a patient are suspended in normal serum they become typically sickle-shaped. Stained smears or freshly made wet preparations generally reveal only a few sickle cells, but wet preparations which are allowed to stand for 24 hours show from 25 to 100 percent sickle cells according to the severity of the disease. Symptoms of the disease may be absent, mild or severe. Generally, only those patients with severe symptoms, such as varying degrees of weakness and anaemia, leg ulcers and muscular pains or stiffness, seek medical advice, but examination of members of their families often reveal the milder cases.

The chart in figure 1 shows the extent of the disease in the family of John T. of Virginia. Here, the father, John T., with sickle cells, and his wife, Annie T., normal, had seven children, of whom five exhibited sickle cells, one was normal, and one died of pneumonia before the study began. Three of the children with sickle cells married normal persons, and, of their children in each case, part were normal and part possessed sickle cells.

¹ From the Department of Medical Zoölogy of the School of Hygiene and Public Health, JOHNS HOPKINS UNIVERSITY, and the Biological Division of the Medical Clinic, JOHNS HOPKINS UNIVERSITY and HOSPITAL. The present note was written by W. H. TALIAFERRO, but is based on the original data of J. G. HUCK.

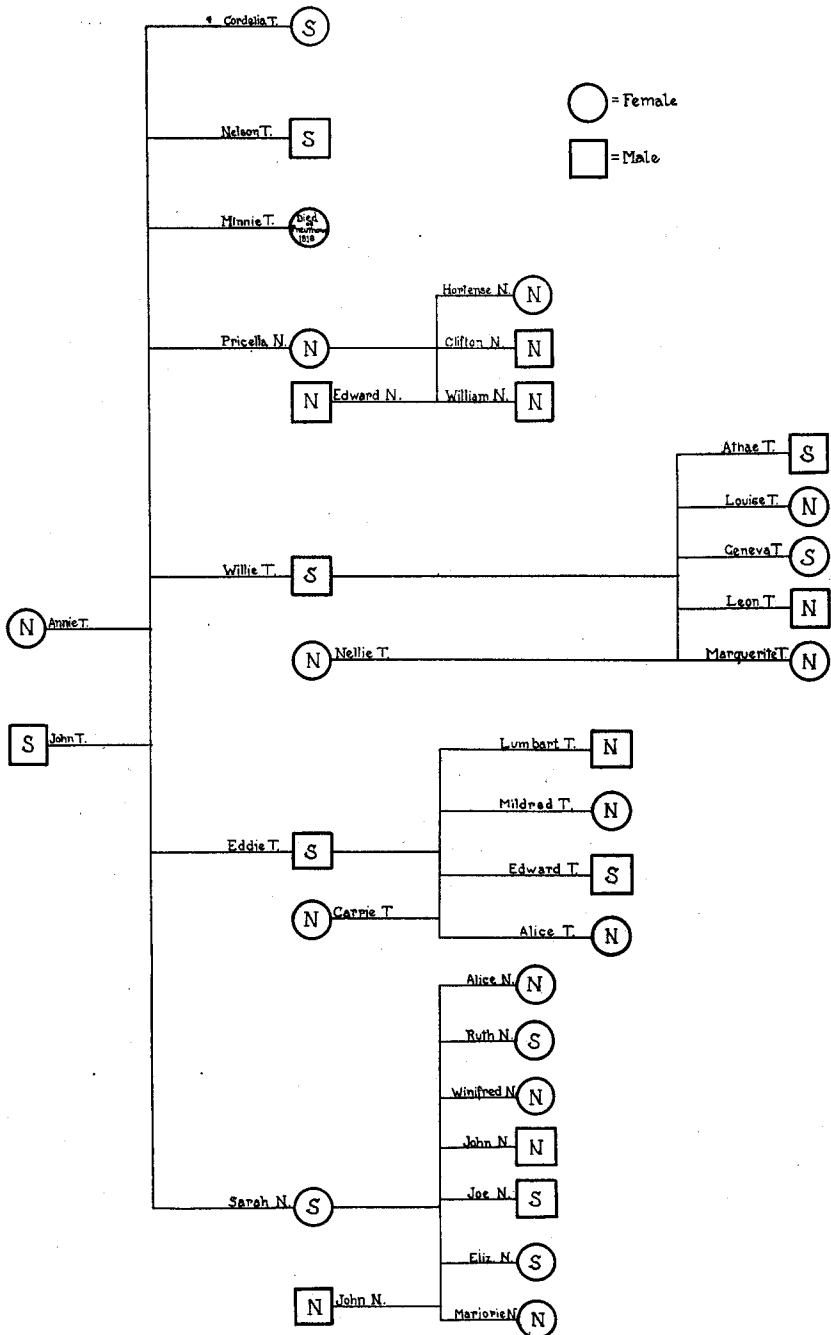
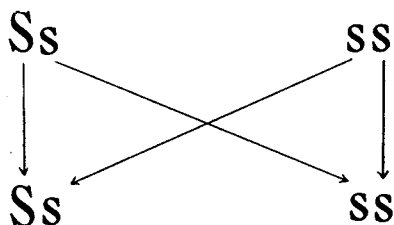

FIGURE 1.—Chart showing the inheritance of sickle cells in the family of John T. of Virginia. *N*, normal, and *S*, sickle cells.

The children of the one normal child who also married a normal person were all normal. In analyzing this chart it seems best to give what we believe to be the correct explanation of the inheritance of sickle cells and follow this with a short discussion of the other possibilities which have been eliminated.

Careful examination of the chart in figure 1 reveals the fact that the character for sickle cells behaves as a single Mendelian character, which is not sex-linked, and which is dominant over the normal condition. Furthermore, John T. seems to be heterozygous for the sickle-cell condition and his wife homozygous for the normal condition. The following diagram shows the results which would be expected under such conditions, where *S* stands for the sickle-cell character and *s* for the normal character.



The fact that of the six F_1 progeny of John T. and Annie T., which were tested, only one was normal, seems a rather poor approximation to the expected 1 : 1 ratio. If, however, John T. is heterozygous, then all of his abnormal children must be heterozygous, and we are justified in averaging the results obtained from the marriage of John T. and Annie T. with the progeny resulting from the marriages of their abnormal children with normal mates. In this way we have four crosses of presumably heterozygous abnormal persons with homozygous normal persons. Resulting from these four crosses, there are 23 children as follows: John T. \times Annie T., 5 abnormal, 1 normal and 1 untested; John N. \times Sarah N., 3 abnormal and 4 normal; Eddie T. \times Carrie T., 1 abnormal and 3 normal; Willie T. \times Nellie T., 2 abnormal and 3 normal. In the total of 23 children, there are 11 abnormal, 11 normal and 1 untested, which gives, among the tested children, an exact 1 : 1 ratio.

Not only are the results charted in figure 1 in accord with the assumption that sickle-cell anaemia behaves as a single Mendelian character which is dominant over the normal condition and is not sex-linked, and that John T. is heterozygous for the abnormal condition, but we have found them to be incompatible with other possible assumptions. It is unnecessary to present all of these, as some of them are obviously unsuitable, but a few should be noted.

1. In the original cross between John T. and Annie T., the former may have been homozygous for the abnormal condition and the one normal child may have been illegitimate. If this be true, however, the children would all be heterozygous, just as when John T. is assumed to be heterozygous, and hence the main conclusion that sickle-cell anaemia behaves as a single dominant Mendelian character would be unaffected.

2. It is obviously impossible to consider the character of sickle cells a sex-linked dominant, because then the F_1 generation would have consisted of only abnormal daughters and normal sons. If, on the other hand, the character were a sex-linked recessive,² and Annie T. were heterozygous for

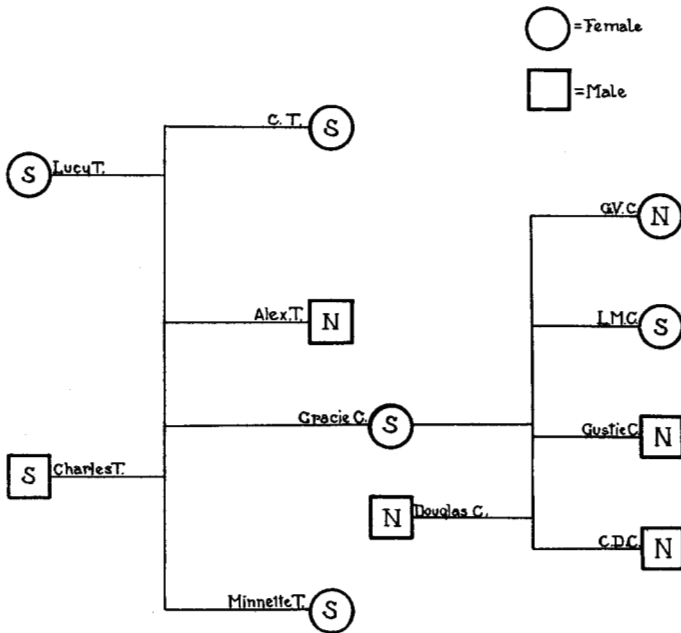

FIGURE 2.—Chart showing the inheritance of sickle cells in the family of Charles T. of Maryland. *N*, normal, and *S*, sickle cells.

the sickle-cell condition, we may assume that the expected ratio of an equal number of normal and abnormal sons and daughters was not obtained because of the smallness of the numbers involved. That this explanation is based on a false assumption, however, is shown by the fact that the F_1 abnormal daughters (who must be homozygous) when mated with

² This analysis of sex-linked inheritance is based on the assumption that in man the male possesses an XY and the female possesses an XX chromosomal complex, as is indicated by the recent work of PAINTER (1923). That this is a correct assumption is also indicated by the behavior of the known sex-linked characters in man.

normal men should have had only normal daughters and abnormal sons, an expectation which is not borne out by the facts.

3. It may be that the character for sickle cells is a non-sex-linked recessive and that Annie T. is heterozygous (John T. being necessarily homozygous), in which case the progeny should consist of an equal number of normal and abnormal children. In this case, however, the only way to explain the results obtained in the F_2 generation would be to assume that each abnormal child married a person heterozygous for the sickle-cell condition. This assumption seems beside the point when we can fit the facts in the case so much more readily as described in our first analysis.

The chart shown in figure 2, which is taken from the data of GUTHRIE and HUCK (1923), contains too few individuals to warrant a detailed analysis. The results are, however, easily explained by assuming, as was done in the first case, that the character for sickle cells is a single Mendelian dominant which is not sex-linked and that both Charles T.³ and Lucy T. are heterozygous for sickle cells. It does, therefore, add further evidence for the correctness of the conclusions reached in the analysis of the first chart.

SUMMARY

Sickle-cell anaemia in man is an inherited condition and behaves as a single Mendelian character which is dominant over the normal condition and which is not sex-linked.

LITERATURE CITED

- GUTHRIE, C. G., and HUCK, J. G., 1923 On the existence of more than four iso-agglutinin groups in human blood. (Part I). *Bull. Johns Hopkins Hosp.* **34**: 37-48.
HUCK, J. G., 1923 Sickle-cell anaemia. *Bull. Johns Hopkins Hosp.* **34**: 335-344.
PAINTER, T. S., 1923 Studies in mammalian spermatogenesis. II. The spermatogenesis of man. *Jour. Exp. Zool.* **37**: 291-336.

³ Although the surnames of the original members of the families shown in the charts in both figures 1 and 2 begin with T., their names are different, they come from different states and are probably not even remotely related.